

94307 Horizontal Flame Arrester

The Shand & Jurs 94307 Horizontal Flame Arrester is designed to provide a positive flame stop in gas piping systems. The 94307 not only provides exceptional protection against propagation of fire, but also offers maximum flow capacity. It is specifically designed to prevent liquid accumulation in the tube bank assembly.

The tube bank design, consisting of a spiral wound crimped ribbon around a solid core, maximizes flow capacity with minimum pressure drop. Standard construction includes cast aluminum, cast steel and 316 stainless steel body materials suitable for most environments. The tube bank is available in aluminum, 304 stainless steel and 316 stainless steel. The 94307 is gasketed for maximum of 10 psi static pressure standard. Higher static pressures available.

Periodic inspection, maintenance and replacement of tube bank is as simple as removing tie-bolts and expanding the remaining jack screws. Once the body sections are expanded, the tube bank and shell are easily removed.

Available with flat face flanges for aluminum or raised face flanges for cast steel and stainless steel to match ANSI, DIN, or JIS 10K specifications.

For in-line deflagration arrester, see the Shand & Jurs 94407.

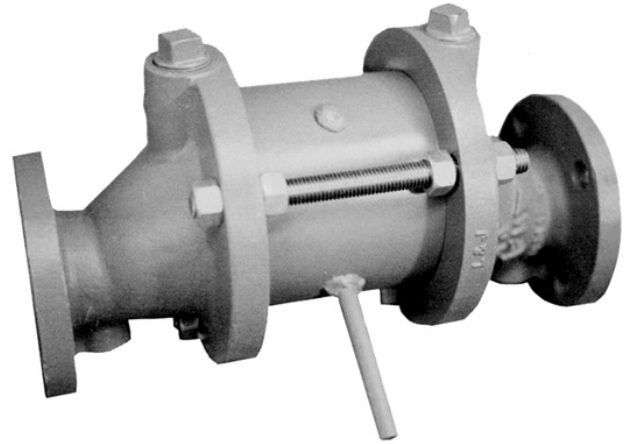

Features

- Unitized tube bank design
- Maximum protection and efficiency with minimum pressure drop
- Wide range of standard construction materials
- Easy inspection and maintenance, due to simple removal of tube bank
- Complete range of sizes from 2" through 12" Consult factory for larger sizes

Specifications

***Sizes:**

2", 3", 4", 6", 8", 10" and 12"
 *Consult Factory for larger sizes

Max. Static Pressure:

10 PSI Standard.
 25 and 50 PSI Consult Factory.

Flange Rating:

To match drilling of ANSI 150 lb. flat face or 150 lb. raised face (cast aluminum body option available with flat face only). DIN and JIS options.

Gas Application:

NEC Group D

Materials of Construction

Body:

Cast Steel, Cast Aluminum, or 316 Stainless Steel

Hardware:

18-8 Stainless Steel (Standard) or 316 Stainless Steel for 316 Stainless Steel Bodies

Tube Bank:

Aluminum, 304 or 316 Stainless Steel

Gaskets:

Synthetic Composition

Outline Dimensions

Dimensions in Inches				
Vent Size	"A"	"B"	Diameter "D"	"F"
2"	14 1/2	8 5/32	6	5/8
3"	16	10 1/16	7 1/2	3/4
4"	20	12 3/16	9	15/16
6"	24 3/8	16 1/64	11	1
8"	32 1/8	20 7/8	13 1/2	1 1/8
10"	33 3/8	24 3/4	16	1 3/16
12"	34 3/8	29 5/16	19	1 1/4

Installation Note: Locate flame arrester within 10 pipe diameters of potential atmospheric ignition source.

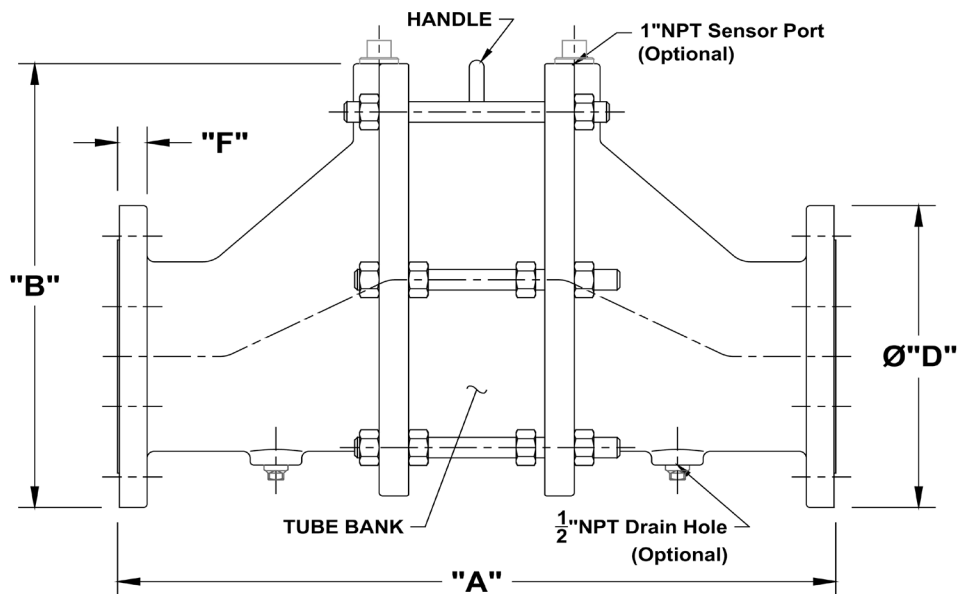

All designs subject to change. Certified dimensions and specifications available upon request.

94307 Ordering Guide

Model Number Selection

The model number will consist of a base number **94307** followed by 6 digit numbers. These digits will represent 2 option tables.

94307 - AB - CD - EF

Ordering Information

Specify:

1. Model 94307 Horizontal Flame Arrester
2. Size and Body Material

3. Tube Bank and Shell Material
4. Type of Flange Option
5. Special Materials or Coatings, If Required

Table AB - Size and Body

Table CD - Tube Bank and Shell

Option AB	Size (Inches)	Body Material	Option CD*	Tube Bank Material	Shell Material
12	2	Cast Aluminum	11 (12)	Aluminum	Aluminum
12	2	Cast Aluminum	66 (67)	304 Stainless Steel	Carbon Steel
12	2	Cast Aluminum	22 (23)	316 Stainless Steel	316 Stainless Steel
12	2	Cast Aluminum	44 (45)	304 Stainless Steel	304 Stainless Steel
14	3	Cast Aluminum	11 (12)	Aluminum	Aluminum
14	3	Cast Aluminum	66 (67)	304 Stainless Steel	Carbon Steel
14	3	Cast Aluminum	22 (23)	316 Stainless Steel	316 Stainless Steel
14	3	Cast Aluminum	44 (45)	304 Stainless Steel	304 Stainless Steel
15	4	Cast Aluminum	11 (12)	Aluminum	Aluminum
15	4	Cast Aluminum	66 (67)	304 Stainless Steel	Carbon Steel
15	4	Cast Aluminum	22 (23)	316 Stainless Steel	316 Stainless Steel
15	4	Cast Aluminum	44 (45)	304 Stainless Steel	304 Stainless Steel
16	6	Cast Aluminum	11 (12)	Aluminum	Aluminum
16	6	Cast Aluminum	66 (67)	304 Stainless Steel	Carbon Steel
16	6	Cast Aluminum	22 (23)	316 Stainless Steel	316 Stainless Steel
16	6	Cast Aluminum	44 (45)	304 Stainless Steel	304 Stainless Steel
17	8	Cast Aluminum	11 (12)	Aluminum	Aluminum
17	8	Cast Aluminum	66 (67)	304 Stainless Steel	Carbon Steel
17	8	Cast Aluminum	22 (23)	316 Stainless Steel	316 Stainless Steel
17	8	Cast Aluminum	44 (45)	304 Stainless Steel	304 Stainless Steel
18	10	Cast Aluminum	11 (12)	Aluminum	Aluminum
18	10	Cast Aluminum	66 (67)	304 Stainless Steel	Carbon Steel
18	10	Cast Aluminum	22 (23)	316 Stainless Steel	316 Stainless Steel
18	10	Cast Aluminum	44 (45)	304 Stainless Steel	304 Stainless Steel
19	12	Cast Aluminum	11 (12)	Aluminum	Aluminum
19	12	Cast Aluminum	66 (67)	304 Stainless Steel	Carbon Steel
19	12	Cast Aluminum	22 (23)	316 Stainless Steel	316 Stainless Steel
19	12	Cast Aluminum	44 (45)	304 Stainless Steel	304 Stainless Steel
32	2	Cast Iron	66 (67)	304 Stainless Steel	Carbon Steel
32	2	Cast Iron	22 (23)	316 Stainless Steel	316 Stainless Steel
32	2	Cast Iron	44 (45)	304 Stainless Steel	304 Stainless Steel
52	2	Cast Steel	66 (67)	304 Stainless Steel	Carbon Steel

Raised Face Flanges Available, not available with Aluminum bodies.

*NOTE: 18-8 Stainless Steel Hardware is Standard.
For 316 Stainless Steel Hardware, use Option CD in (XX).

94307**Horizontal Flame Arrester****Table AB - Size and Body****Table CD - Tube Bank and Shell**

Option AB	Size (Inches)	Body Material	Option CD*	Tube Bank Material	Shell Material
52	2	Cast Steel	22 (23)	316 Stainless Steel	316 Stainless Steel
52	2	Cast Steel	44 (45)	304 Stainless Steel	304 Stainless Steel
42	2	Cast 316 Stainless Steel	22 (23)	316 Stainless Steel	316 Stainless Steel
34	3	Cast Iron	66 (67)	304 Stainless Steel	Carbon Steel
34	3	Cast Iron	22 (23)	316 Stainless Steel	316 Stainless Steel
34	3	Cast Iron	44 (45)	304 Stainless Steel	304 Stainless Steel
54	3	Cast Steel	66 (67)	304 Stainless Steel	Carbon Steel
54	3	Cast Steel	22 (23)	316 Stainless Steel	316 Stainless Steel
54	3	Cast Steel	44 (45)	304 Stainless Steel	304 Stainless Steel
44	3	Cast 316 Stainless Steel	22 (23)	316 Stainless Steel	316 Stainless Steel
35	4	Cast Iron	66 (67)	304 Stainless Steel	Carbon Steel
35	4	Cast Iron	22 (23)	316 Stainless Steel	316 Stainless Steel
35	4	Cast Iron	44 (45)	304 Stainless Steel	304 Stainless Steel
55	4	Cast Steel	66 (67)	304 Stainless Steel	Carbon Steel
55	4	Cast Steel	22 (23)	316 Stainless Steel	316 Stainless Steel
55	4	Cast Steel	44 (45)	304 Stainless Steel	304 Stainless Steel
45	4	Cast 316 Stainless Steel	22 (23)	316 Stainless Steel	316 Stainless Steel
36	6	Cast Iron	66 (67)	304 Stainless Steel	Carbon Steel
36	6	Cast Iron	22 (23)	316 Stainless Steel	316 Stainless Steel
36	6	Cast Iron	44 (45)	304 Stainless Steel	304 Stainless Steel
56	6	Cast Steel	66 (67)	304 Stainless Steel	Carbon Steel
56	6	Cast Steel	22 (23)	316 Stainless Steel	316 Stainless Steel
56	6	Cast Steel	44 (45)	304 Stainless Steel	304 Stainless Steel
46	6	Cast 316 Stainless Steel	22 (23)	316 Stainless Steel	316 Stainless Steel
37	8	Cast Iron	66 (67)	304 Stainless Steel	Carbon Steel
37	8	Cast Iron	22 (23)	316 Stainless Steel	316 Stainless Steel
37	8	Cast Iron	44 (45)	304 Stainless Steel	304 Stainless Steel
57	8	Cast Steel	66 (67)	304 Stainless Steel	Carbon Steel
57	8	Cast Steel	22 (23)	316 Stainless Steel	316 Stainless Steel
57	8	Cast Steel	44 (45)	304 Stainless Steel	304 Stainless Steel
47	8	Cast 316 Stainless Steel	22 (23)	316 Stainless Steel	316 Stainless Steel
38	10	Cast Iron	66 (67)	304 Stainless Steel	Carbon Steel
38	10	Cast Iron	22 (23)	316 Stainless Steel	316 Stainless Steel
38	10	Cast Iron	44 (45)	304 Stainless Steel	304 Stainless Steel
58	10	Cast Steel	66 (67)	304 Stainless Steel	Carbon Steel
58	10	Cast Steel	22 (23)	316 Stainless Steel	316 Stainless Steel
58	10	Cast Steel	44 (45)	304 Stainless Steel	304 Stainless Steel
48	10	Cast 316 Stainless Steel	22 (23)	316 Stainless Steel	316 Stainless Steel
39	12	Cast Iron	66 (67)	304 Stainless Steel	Carbon Steel
39	12	Cast Iron	22 (23)	316 Stainless Steel	316 Stainless Steel
39	12	Cast Iron	44 (45)	304 Stainless Steel	304 Stainless Steel
59	12	Cast Steel	66 (67)	304 Stainless Steel	Carbon Steel
59	12	Cast Steel	22 (23)	316 Stainless Steel	316 Stainless Steel
59	12	Cast Steel	44 (45)	304 Stainless Steel	304 Stainless Steel
49	12	Cast 316 Stainless Steel	22 (23)	316 Stainless Steel	316 Stainless Steel

Raised Face Flanges Available, not available with Aluminum bodies.

*NOTE: 18-8 Stainless Steel Hardware is Standard. For 316 Stainless Steel Hardware, use Option CD in (XX).

5911 Butterfield Road Hillside, IL 60162 • tel: (708) 236-6000 • fax: (708) 236-6006
sales@ljtechnologies.com • www.ljtechnologies.com • ISO 9001:2008 Certified

Rev: 94307-3A

Table EF - Flange Type and Drain Plugs

Flange Style	No Drain Plugs Option EF	With Drain Plugs Option EF
ANSI FF	77	71
ANSI RF	87	81
DIN 2633 FF	27	21
DIN 2633 RF	37	31
JIS 10K FF	47	41
JIS 10K RF	57	51

Tube Banks Only

Parts Number	Size (Inches)	Tube Bank Material	Shell Material	Shipping Weight (lbs.)
9430-10150	2	Aluminum	Aluminum	9
091211	2	304 Stainless Steel	Carbon Steel	22
9430-11120	2	304 Stainless Steel	304 Stainless Steel	25
9430-11110	2	316 Stainless Steel	316 Stainless Steel	25
9430-10151	3	Aluminum	Aluminum	14
091212	3	304 Stainless Steel	Carbon Steel	30
9430-11121	3	304 Stainless Steel	304 Stainless Steel	35
9430-11111	3	316 Stainless Steel	316 Stainless Steel	35
9430-10152	4	Aluminum	Aluminum	20
091213	4	304 Stainless Steel	Carbon Steel	55
9430-11122	4	304 Stainless Steel	304 Stainless Steel	60
9430-11112	4	316 Stainless Steel	316 Stainless Steel	60
9430-10153	6	Aluminum	Aluminum	35
9430-11070	6	304 Stainless Steel	Carbon Steel	90
9430-11123	6	304 Stainless Steel	304 Stainless Steel	100
9430-11113	6	316 Stainless Steel	316 Stainless Steel	100
9430-10154	8	Aluminum	Aluminum	55
9430-11071	8	304 Stainless Steel	Carbon Steel	145
9430-11124	8	304 Stainless Steel	304 Stainless Steel	160
9430-11114	8	316 Stainless Steel	316 Stainless Steel	160
9430-10155	10	Aluminum	Aluminum	85
9430-11072	10	304 Stainless Steel	Carbon Steel	225
9430-11125	10	304 Stainless Steel	304 Stainless Steel	240
9430-11115	10	316 Stainless Steel	316 Stainless Steel	240
9430-10156	12	Aluminum	Aluminum	120
9430-11073	12	304 Stainless Steel	Carbon Steel	310
9430-11126	12	304 Stainless Steel	304 Stainless Steel	320
9430-11116	12	316 Stainless Steel	316 Stainless Steel	320